

Get Peace of Mind with the *PREFERRED* Warranty Program

EXCLUSIVELY FOR LANDSTAR BCOs

Since 1983, NTP® has provided coverage on major mechanical components like engine, aftertreatment, turbo's, injectors, transmission, water pumps and more. Having these critical components covered when they fail gives you peace of mind that NTP will take care of repairs on covered equipment and get you back on the road as quickly as possible...so you're earning again.

An Affordable and Smart Way to Protect Your Business

The NTP warranty program is both affordable and easy to manage for every BCO. You choose the program that works best for you and premiums are deducted weekly from your BCO settlement. So, for less than \$29 you can protect your business and livelihood from an unexpected equipment failure that would cost you thousands of out of pocket dollars to fix. So why take the risk? Pick the program terms and coverage that works best for you, and your business and drive with peace of mind.

Covered Components	10 years old or newer from current year		More than 10 years old from current year	
	12 months/ 100K Miles	24 months/ 200K Miles	12 months/ 100K Miles	24 months/ 200K Miles
Engine, Trans, Rears	\$34.04/wk	\$28.29/wk	\$48.53/wk	\$37.95/wk
Engine, Trans, Rears, Critical Components	\$55.89	\$46.69	\$70.37	\$56.37
Engine, Trans, Rears, Critical Components, Aftertreatment	\$77.88	\$62.78	N/A	N/A
Comfort Package	\$10.12	\$6.67	\$10.12	\$6.67

Comfort Package must be purchased with an equipment warranty program. See new *PREFERRED* coverage details on back.

YOUR TRUCK IS YOUR LIVELIHOOD

A National Truck Protection *PREFERRED* warranty is an investment in your business that gives you:

- 1 Peace of mind**
Rest easy knowing you're covered if something goes wrong with the equipment covered by your warranty.
- 2 Financial protection**
Protect against expensive mechanical issues that can derail your business.
- 3 Essential coverage**
Protect the most important parts of your truck, like the engine, turbo(s), transmission, aftertreatment and more.
- 4 Exceptional customer service**
Fast, responsive 24/7 customer service means you always have the help you need, when you need it.
- 5 Impressive payouts**
We're in the business of keeping you on the road. National Truck Protection pays tens of millions of dollars in claims annually.



Major Components Repair Costs Range

The high cost to repair one major equipment failure could put your business in jeopardy. A National Truck Protection warranty will protect your business, your investment and your livelihood.

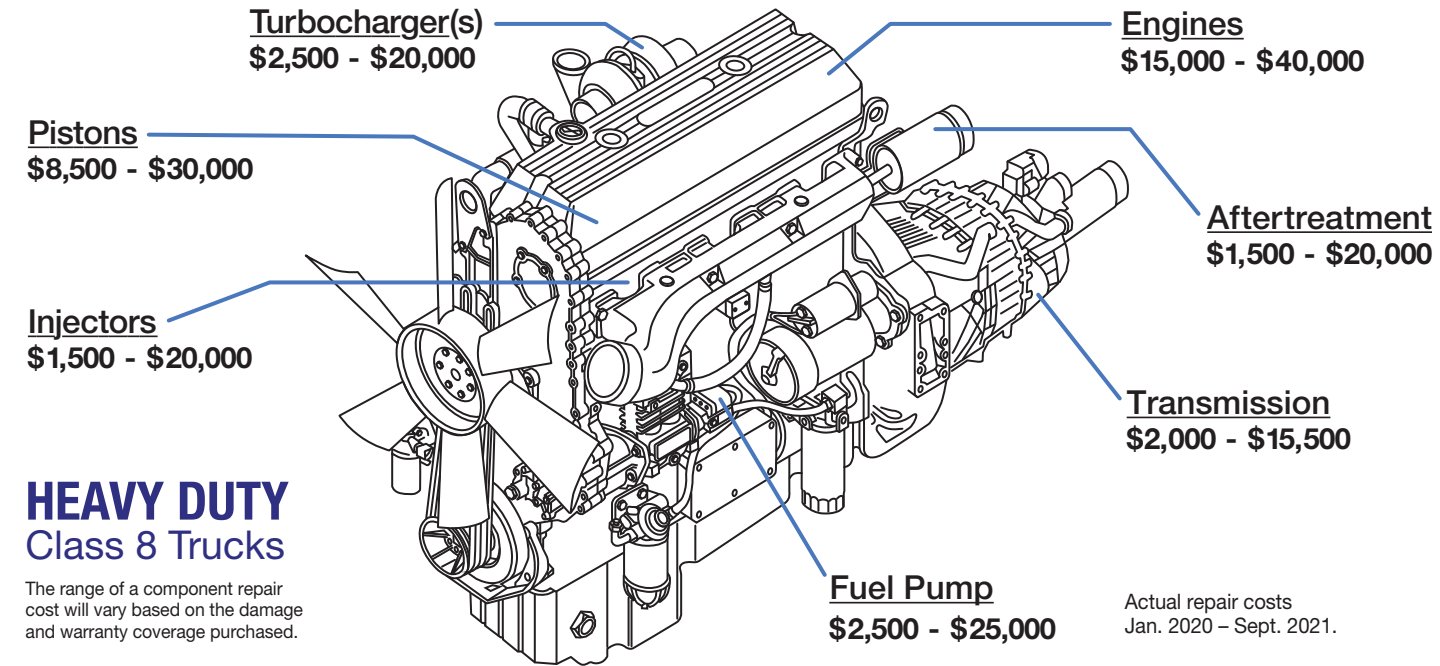

Since 1983, our mission has been to keep you and your truck on the road and moving. That's why we are always designing the industry's best warranty programs to protect your most important asset. And when you need us, we'll be there to provide outstanding customer service to get you back on the road as quickly and safely as possible.

For more information on the NTP Preferred Warranty program for Landstar BCOs, email us at landstarcoord@ajg.com. An AJ Gallagher representative will be happy to tell you more and sign you up for an NTP warranty, and a little peace of mind.

High Risk of Equipment Failure After Factory Warranty Ends

Cost of Repairs for Claims Paid

Example of Basic Warranty Coverage for New HD/MD Trucks

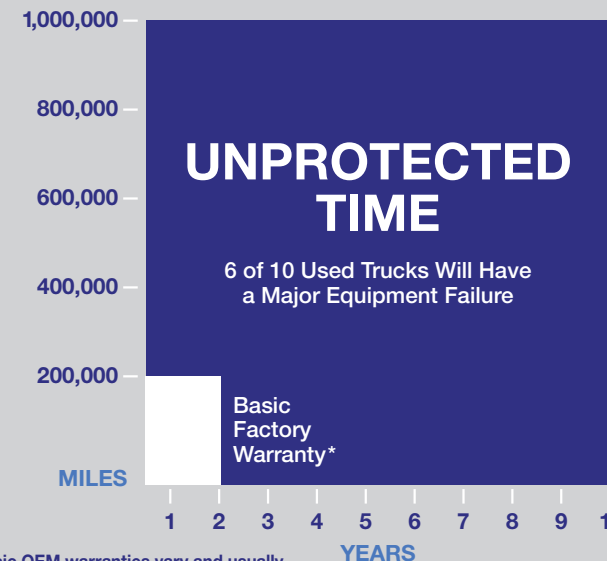

- 64% of paid claims have repair costs over \$5,000
- Nearly 1 in 4 claims had repair costs over \$10,000

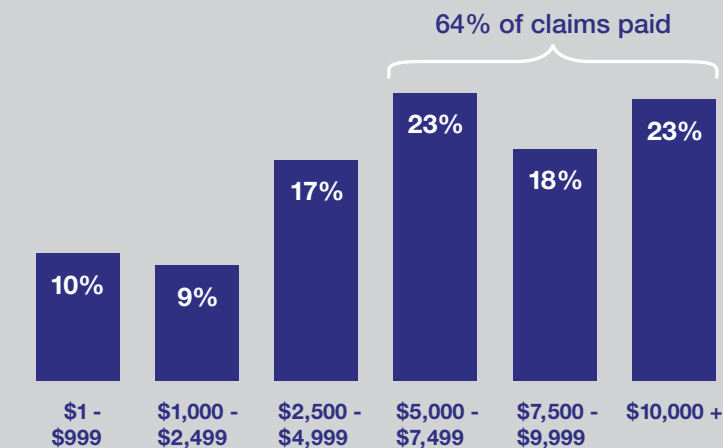

* Basic OEM warranties vary and usually include engine and sometimes transmission.

Costs are actual total repairs paid for warranties reaching full term Jan. 2020 – Sept. 2021.

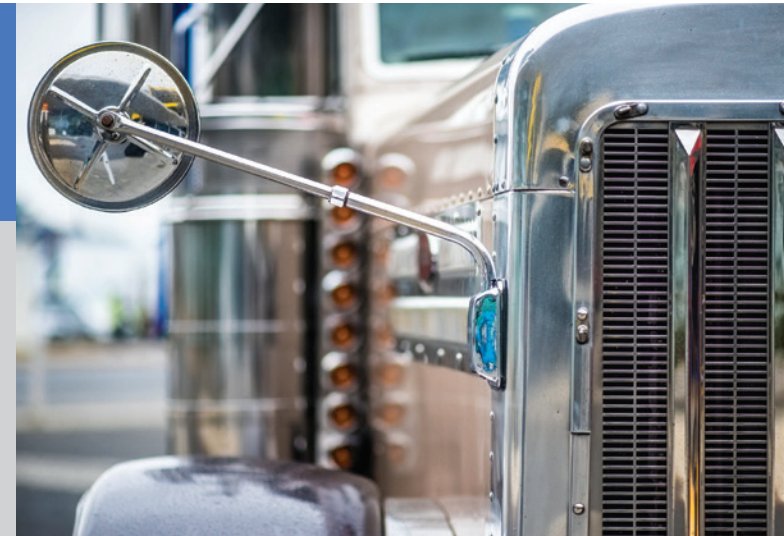

For more information, call or email us.

1-800-435-0372

landstarcoord@ajg.com

NTP PREFERRED Warranty Program

Covered Components

CC = Included in Critical Components
LOL = Limits of Liability

Coverage Exclusions: Please refer to your contract for complete list and details of covered and non-covered items.

Engine (LOL \$22,500)

Engine's internally lubricated hard parts:

- Camshaft and Cam Bearings
- Cam Followers
- Connecting Rods
- Connecting Rod Bearings
- Connecting Rod Caps and Screws
- Crankshaft
- Cylinder Block Casting
- Cylinder Head
- Cylinder Head Gasket
- Cylinder Liners
- Cylinder Head Bolts
- Hydraulic Lifters
- Injector Cups
- Intake and Exhaust Valves
- Intake and Exhaust Valve Guides
- Main Bearings
- Oil Cooler and Housing
- Oil Pan
- Oil Pump Pick Up Screen
- Oil Pump Pick Up Tube*
- Oil Pump Pressure Relief Springs and Valves
- Pistons, Piston Rings and Piston Oil Cooling Jets
- Pushrods
- Rocker Arms and Rocker Arm Shafts
- Thrust Washers
- Timing Gears
- Timing Gear Cover and Housing
- Valve Cover
- Valve Retainers and Keepers (Locks)
- Valve Seats
- Valve Springs
- Wrist Pins

"Non-oil" related components:

- Exhaust Manifold
- Flywheel Housing
- Intake Manifold
- Thermostat Housing
- Vibration Dampener

* For Detroit Diesels, breakdowns originating from the "oil pump pick up tube O-ring" will only be covered if the TSB D18M3 has been performed by a certified OEM repair shop.

Transmission (LOL \$7,500)

Internally lubricated hard parts of the manual or automatic transmission include:

- Bands
- Bearings
- Blockers
- Bushings
- Drums
- Gear Sets
- Governor
- Oil Pump
- Shaft(s)
- Shift Forks
- Synchronizers
- Thrust Washers
- Torque Converter
- Valve Body

Differential (LOL \$7,500)

Internally lubricated hard parts include:

- Axle Housing
- Axle Shafts
- Bearings
- Bushings
- Carrier Case
- Gear Sets
- Limited Slip Clutch Pack

Power divider includes:

- Bearings
- Gears
- Shafts
- Shift Forks

(CC) Turbo (LOL \$7,500)

Turbochargers include:

- Bearings
- Internal Variable Vane Assembly
- Turbine and Turbine Shaft
- Turbo Actuator

(CC) Engine Fuel Injectors, Water Pump, Fuel Pump & ECM (LOL \$5,000)

- Complete Injector
- Fuel Injector Hard Lines
- Fuel Injection Pump
- Fuel Pump
- Engine Control Module (ECM)
- Water Pump

Progressive Damage, Wearout & Carbon Packing

Please refer to your contract for details on Progressive Damage, Wearout & Carbon Packing coverage.

Aftertreatment, Model Year 2014 & Older (LOL \$7,000)

- Aftertreatment Electronic Control Module (ACM)
- Diesel Exhaust Fluid (DEF) Module with Injection Nozzle
- DEF Tank
- Diesel Oxidation Catalyst (DOC)
- DOC Doser Injector
- Diesel Particulate Filter (DPF)
- DPF Dosing Module
- Exhaust Gas Recirculation (EGR) Valves
- EGR Cooler(s)
- Hydrocarbon Doser Injector (HC Doser, 7th Injector, ARD, AHI Module)
- Selective Catalytic Reduction (SCR) Catalyst
- Sensor, Lambda (O₂ Sensor)
- Sensor, NOx (2)

Aftertreatment, Model Year 2015 & Newer (LOL \$8,000)

- Aftertreatment Electronic Control Module (ACM)
- Back Pressure Control Valve (BPV)
- Diesel Exhaust Fluid (DEF) Module with Injection Nozzle
- DEF Heater Control Relay
- DEF Dosing Module - Wiring Harness
- DEF Heated Lines (3)
- DEF Heater Coolant Control Valve
- DEF Heating Elements
- DEF Heating Fittings (3 on Supply Module)
- DEF Pump and Module
- DEF Solution Level/Temperature Sensor
- DEF Tank
- Diesel Oxidation Catalyst (DOC)
- Diesel Particulate Filter (DPF)
- DPF Air, Fuel, and Coolant Lines
- DPF Air, Fuel, Manifold Assembly
- DPF Dosing Module
- Exhaust Gas Recirculation (EGR) Valves
- EGR Actuator
- EGR Connecting Bellows and Clamps
- EGR Cooler(s)
- Exhaust Piping, Clamps, and Gaskets
- Exhaust Throttle Valve
- Hydrocarbon Doser Injector (HC Doser, 7th Injector, ARD, AHI Module)
- Hydrocarbon Doser Valve - Air, Fuel, and Coolant Lines; and Inline Air Filter
- Hydrocarbon Doser Valve (Voss Valve)
- Selective Catalytic Reduction (SCR) Catalyst
- SCR Decomposition Pipe and Pipe Elbows
- Sensor, BPV Pressure
- Sensor, Delta P (DPF Pressure)
- Sensor, DOC Inlet Pressure
- Sensor, DOC (Post) Temperature
- Sensor, DOC (Pre) Temperature
- Sensor, DPF Air Supply Pressure
- Sensor, DPF Back Pressure
- Sensor, DPF Fuel Pressure
- Sensor, Lambda (O₂ Sensor)
- Sensor, NOx (2)
- Sensor, Pressure After Exhaust Throttle Valve
- Sensor, SCR (Post) Temperature
- Sensor, SCR (Pre) Temperature
- Wiring Harness - Emission Systems (including overlay)

NEW Comfort Package

The Comfort Package covers components in the engine compartment that keep you comfortable in the cabin.

Covered Components:

- Alternator
- Charge Air Cooler
- Engine Air Compressor
- Fan Clutch
- Fuel Tanks, Cap & Valve
- HVAC Air Compressor & Pulley
- HVAC Blower Motor & Resistor
- HVAC Fan Hub
- HVAC Heater Core
- HVAC Temperature Controls, Control Head & Control Valves
- Radiator & Radiator Cap
- Radio
- Starter & Starter Solenoid

Comfort Package must be purchased with an equipment warranty program

RAPID REPAIR GUARANTEE

No other warranty company offers a guarantee on getting you in and out of the repair facility when you need service.

As part of the *PREFERRED* warranty program we guarantee that your truck will be back on the road in a timely manner, or we'll make your truck's monthly finance payment. See program details on our website.

Underwriting

- There is a 30-day waiting period following the month of enrollment



NEW

PREFERRED
WARRANTY PROGRAM
EXCLUSIVE FOR
LANDSTAR

